



Address: 29799 SW Town Center Loop E, Wilsonville, OR, 97070
Phone: (503) 570-1553 □ Fax: (503) 682-7025 □ www.ci.wilsonville.or.us

**Accessibility to Existing Buildings
Tenant Improvement Alterations Compliance Report**

ORS, Section 447.241 (OSSC, Section 1113) states that every project for renovation, alteration, or modification to affected buildings and related facilities that affects or could affect the usability of or access to an area containing a **primary function** shall be made to ensure that, to a maximum extent feasible, the paths of travel to an altered area and the rest rooms, telephones, and drinking fountains serving the altered area are readily accessible and useable by individuals with disabilities, unless such alterations are disproportionate to the overall alterations in terms of cost and scope. Disproportionate shall mean all monies expended that exceeds 25% of the value of the work under consideration.

Permit Value: \$ _____ 25% =: _____

Applicant: _____ Permit No.: BB _____

***NOTE: Standard building maintenance such as rewiring, re-siding, window and door replacement and re-roofing is not considered an alteration and would not be required to be included in the 25% valuation.**

In choosing which accessible elements to provide under ORS 447.241, **priority shall be given to those elements that will provide the greatest access. Elements shall be provided in the following order:**

1. Parking (requires a site plan at application)
2. An accessible entrance
3. An accessible route to the altered area
4. At least one accessible restroom for each sex or a single unisex restroom
5. Accessible telephones
6. When possible, additional accessible elements such as storage and alarms

NOTE: The inspector will be field verifying compliance with this section of the code and may identify items that could be different from what was provided by you on this form. You are required under the provisions of this code, to spend up to 25% of the value of this work to remove barriers within this structure regardless of the scope of your work, starting with the parking space. Acceptance of this form and the information contained is not an approval only a method of collecting information.

Check One

Building is fully compliant. The building has been assessed by the applicant to Chapter 11 of the OSSC and found to be compliant.

Building is not compliant and the following barriers will be removed:

- 1.
- 2.
- 3.
- 4.

Signature: _____

Phone: _____

Printed name: _____

MINIMUM STANDARD SINGLE-DISABLED PERSON PARKING SPACE



OR20-6B SIGN

OR20-6D SIGN

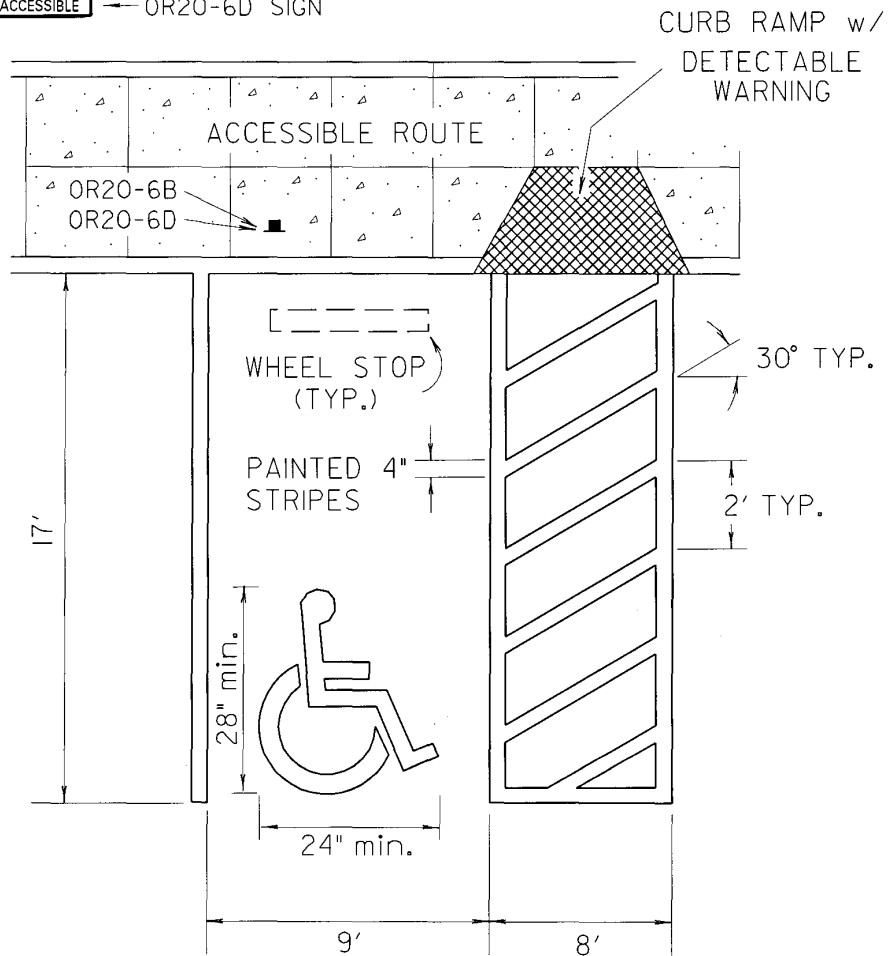

SIGNSTDPG.FL8

WHITE STRIPING AND PAVEMENT STENCIL REQUIRED
STROKE WIDTH ON SYMBOL IS 3" MINIMUM
BLUE BACKGROUND AND BLUE PAINTED CURB OPTIONAL

MINIMUM STANDARD DOUBLE-DISABLED PERSON PARKING SPACE



← OR20-6B SIGN

← OR20-6D SIGN

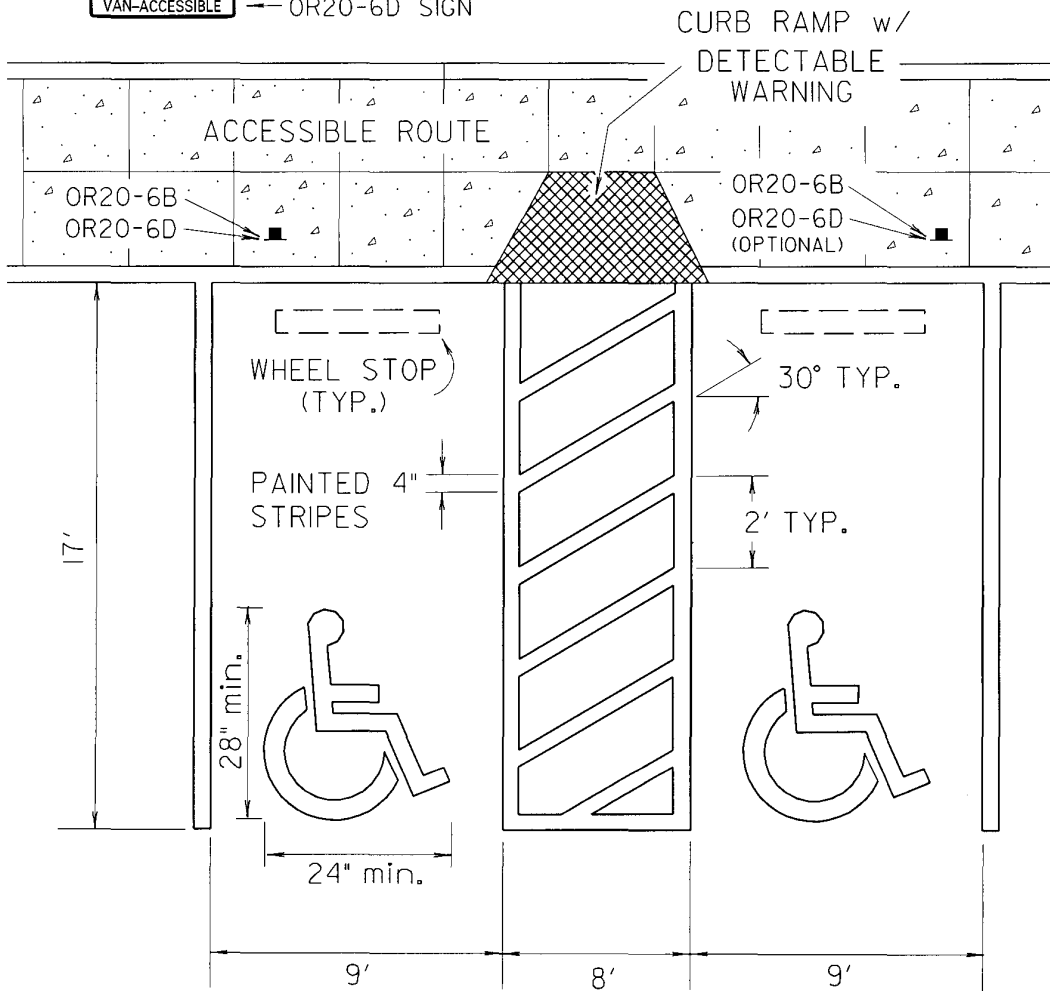

SIGNSTDPG.FL8

WHITE STRIPING AND PAVEMENT STENCIL REQUIRED
STROKE WIDTH ON SYMBOL IS 3" MINIMUM
BLUE BACKGROUND AND BLUE PAINTED CURB OPTIONAL

Sign No. OR20-6D

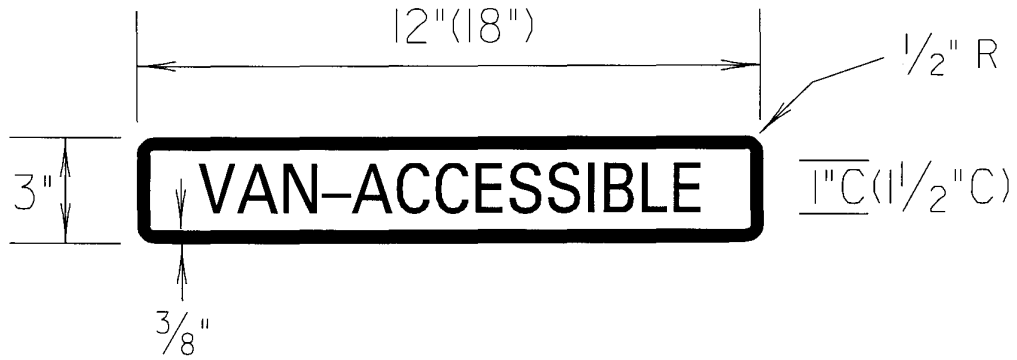

Sign Background: Blue, Retroreflective sheeting

Sign Legend: White, Retroreflective

The VAN-ACCESSIBLE sign shall only be used with sign OR20-6B to designate these parking spaces that have an 8-foot aisle.

SIGNSTDPG.F.11

OREGON DEPARTMENT OF TRANSPORTATION

Approved By: O.T.C.

Date: 1/92

Publication Date: 12/01

THIS SHEET INCLUDED AT REQUEST OF STATE BUILDING CODES DIVISION

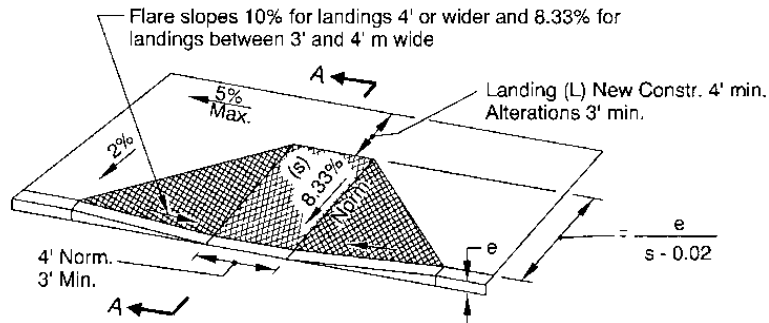

PERPENDICULAR SIDEWALK RAMP DETAIL

(Use "Parallel or Combined Ramp Detail" when reqd. landing cannot be obtained)

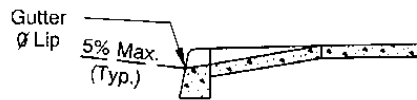

SECTION A-A

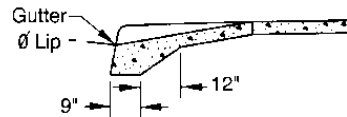

SECTION A-A WITH MONOLITHIC CURB & SIDEWALK

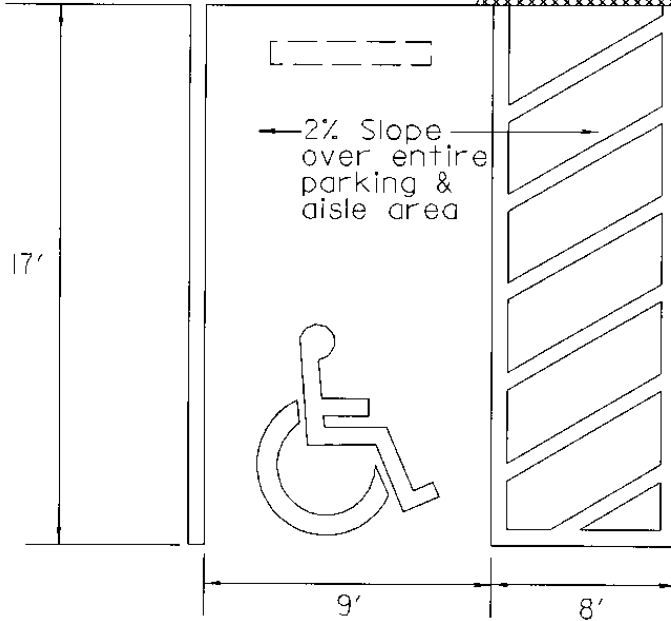
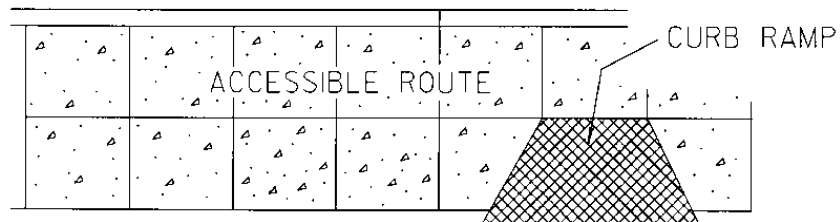

Vertical clearance not less than 98" over entire parking & aisle area.

SIGNSTDPG.FL8

MARKED CROSSING AT VEHICULAR AREAS IN PARKING LOTS

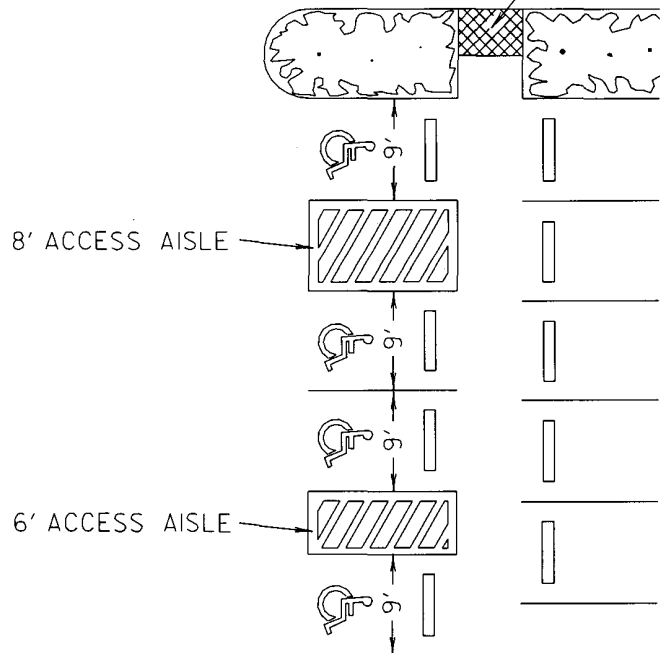
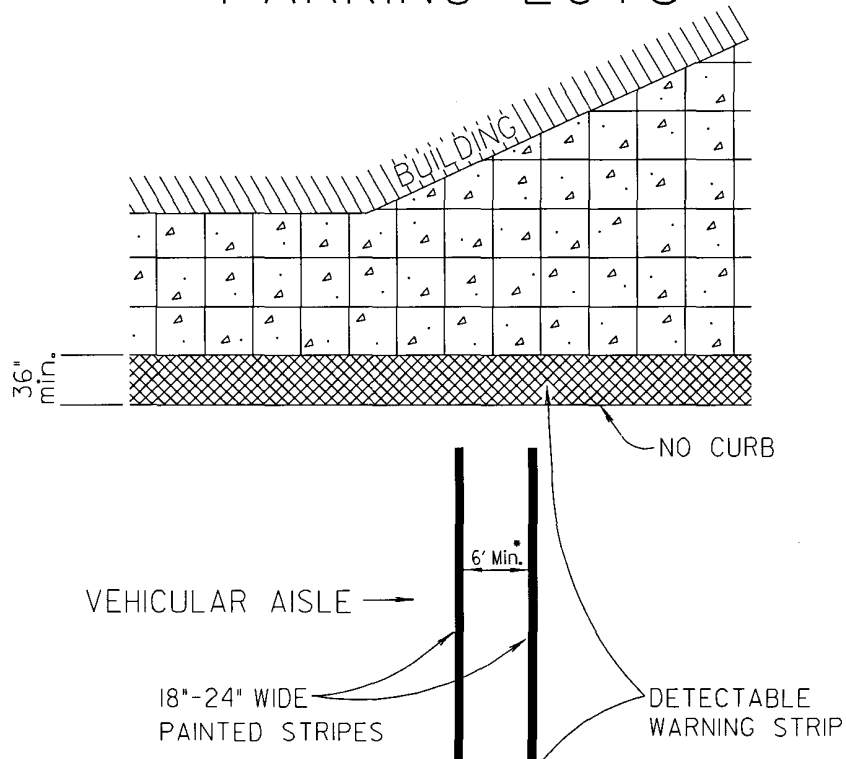

* Type and width of crosswalk may vary from illustration.

ACCESSIBLE PARKING PLAN (2)

Striping and pavement stencil required
(White preferred)

SIGNSTDPG.FL8

Pages 13-29

Figures 1-38, 2007 Oregon Structural Specialty Code, Chapter 11, *Accessibility*

Pages 28-33

Figures 39-44, December 20, 2001, Oregon Department of Transportation, *Disabled Parking Standards*

